

# CDS1820-MEC mechanical devices - Measurement range 0 up to 20 000 mm

## Specifications:

Measurement range	0 up to 20 000 mm
Circumference drum	500 mm/turn
Sensing device	Adaptable with all of our incremental or absolute encoders
Material	Body and cover - aluminium (RohS) Measuring cable - Stainless steel
Cable diameter	0,90 mm
Standard linearity	+/- 0,05% f.s. +/- 0,01% f.s. (optional)
Max. Velocity	10 m/s
Max. Acceleration	2 m/s <sup>2</sup> (before cable deformation)
Weight	≈ 12kg
Operating temperature	-20° to +80°C
Storage temperature	-30° to +80°C



## Cable forces:

Measurement range in mm	Min. pull-out force	Max. pull-out force
20 000	≈ 15,00 N	≈ 30,00 N

## Ordering reference:

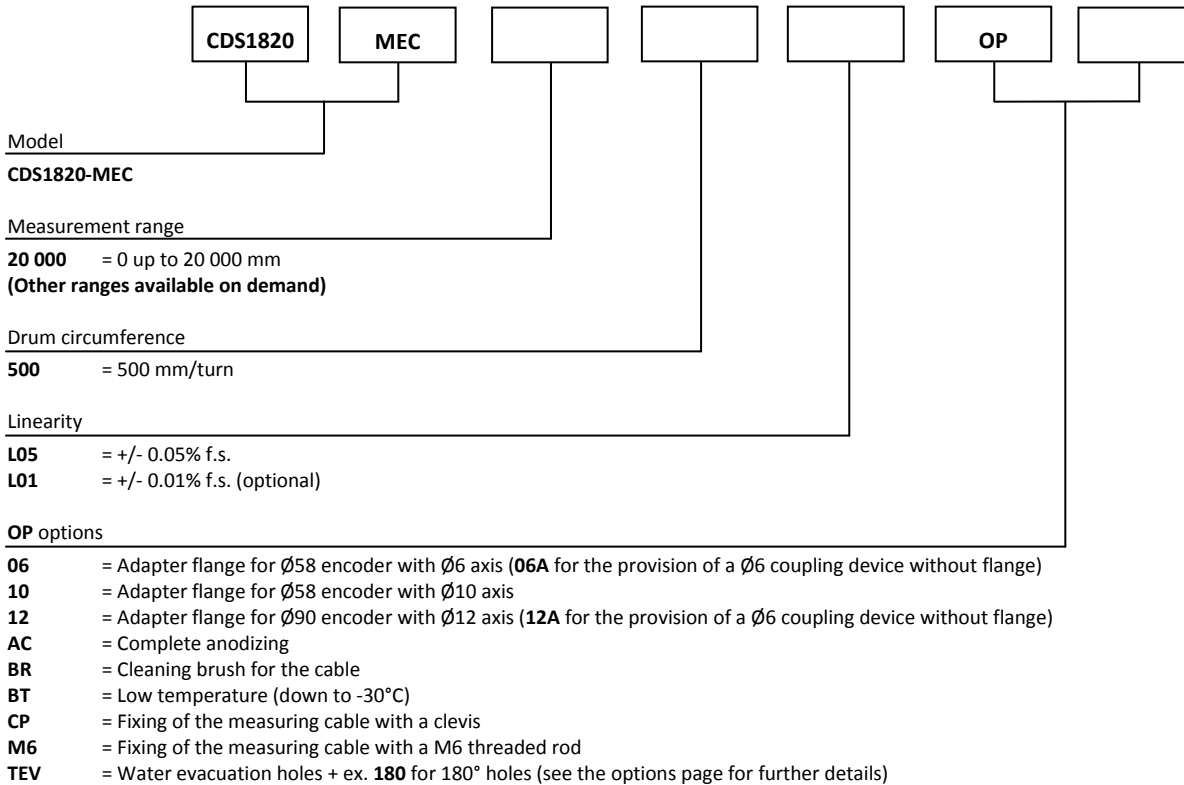

If no option is specified for the adapter flange, the draw-wire sensor will be supplied as standard with a Ø10 coupling brace without a flange. For the adaptation of an encoder or other sensor device which does not belong to our range, please contact us.

Reference example: CDS1820-MEC-20000-500-L05-OP-10-AC



Tel : +33 (0)3 88 02 09 02 / Fax : +33 (0)3 88 02 09 03 / E-mail : info@ak-industries.com / Web : http://www.ak-industries.com

**Options:**

**Cable attachment head:**

**Standard**

Measuring cable attachment with a lug. The attachment mounted on ball bearings allows a free rotation relative to the measurement cable.

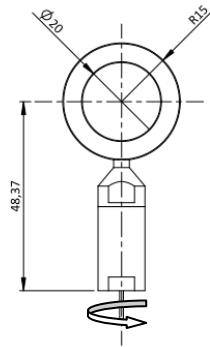

**Cable attachment fitted with a M6 threaded rod:**

**OP-M6**

The rod attachment uses a threaded rod with 2 nuts (provided). The required thickness of the plate does not exceed 8mm.

The attachment mounted on ball bearings allows a free rotation relative to the measurement cable.

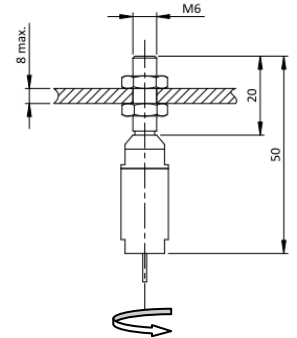

**Cable attachment with a clevis :**

**OP-CP**

The attachment of the clevis is done using a pin (provided). The attachment mounted on ball bearings allows a free rotation relative to the measurement cable.

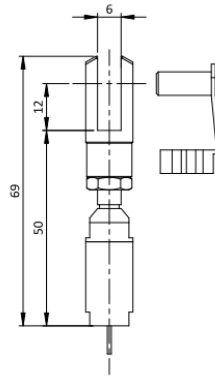

**Cleaning brush for the cable:**

**OP-BR**

The cleaning brush wipes the cable in dusty or humid environments.

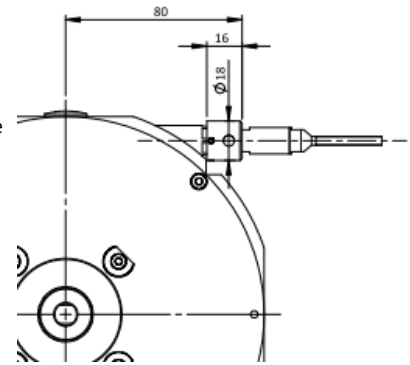

**Water evacuation holes:**

**OP-TEV**

The holes allow the natural flow of fluids out of the sensor in order to avoid their accumulation in the system.

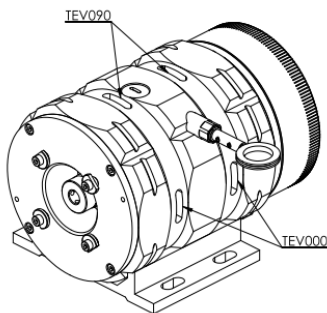

Please specify the implantation angle of the drain holes on the drawing below.  
(All value between 0 and 360°)

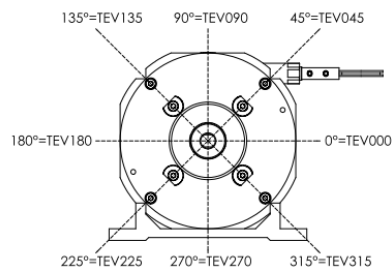

## Adapter flanges

### Adaptation for an encoder of diameter 58mm, and shaft diameter 6mm

OP-06: Adaptation flange +  $\varnothing 6$  Oldham coupling

OP-06A:  $\varnothing 6$  Oldham coupling without adaptation flange

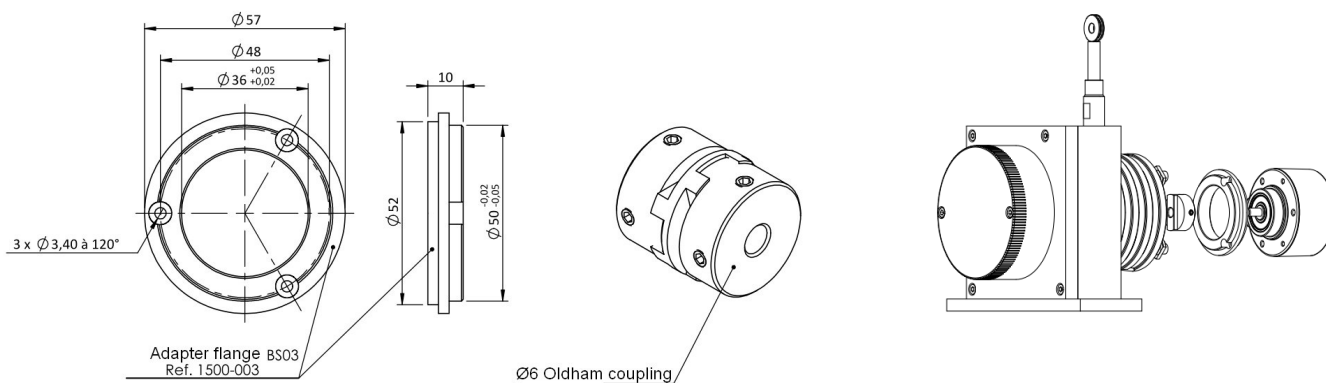

### Adaptation for an encoder of diameter 58mm, and shaft diameter 10mm

OP-10: Adaptation flange +  $\varnothing 10$  Oldham coupling

Without specification, a MEC series draw-wire sensor will always be delivered with an Oldham coupling  $\varnothing 10$  without adaptation flange.

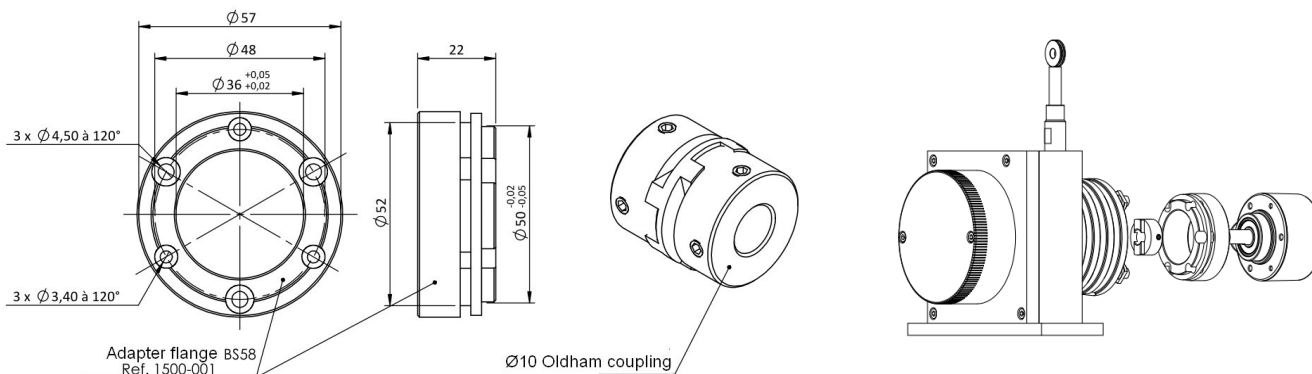

### Adaptation for an encoder of diameter 90mm, and shaft diameter 12mm

OP-12: Adaptation flange +  $\varnothing 12$  Oldham coupling

OP-12A:  $\varnothing 12$  Oldham coupling without adaptation flange

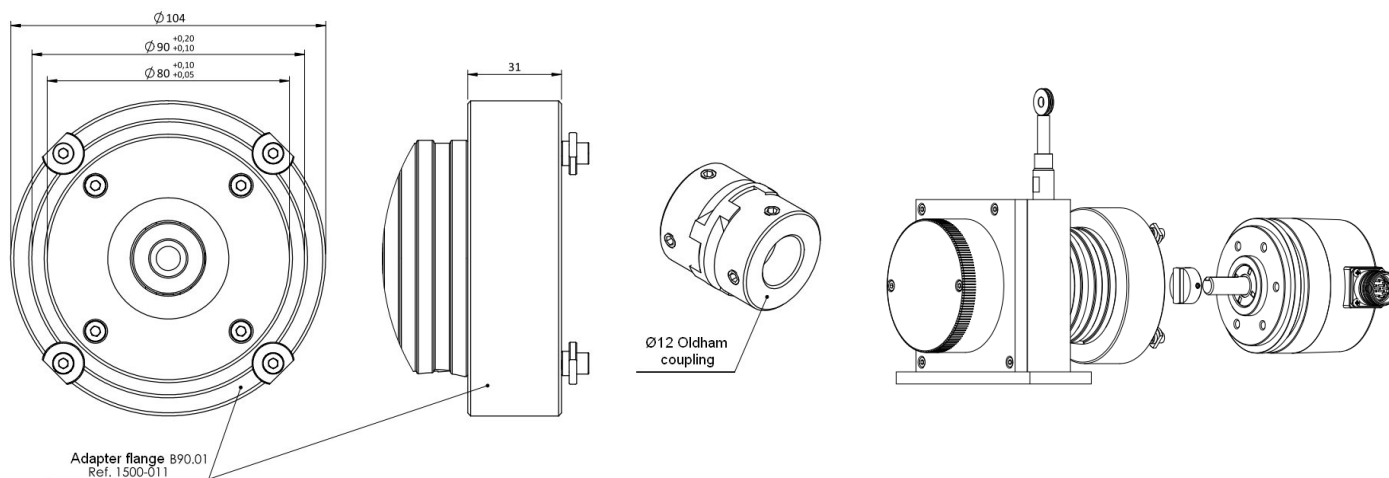

**Dimensional Drawing**

